

Model:

# LSG Equipoise™ LED Lamp

## Instructions and assembly Information

**superlux**  
we engineer light

**With care and attention to the following information your LSG lamp will give you years of satisfactory service.**

- Unpack Lamp Arm assembly and Clamp Base and power cord.
- Choose a suitable position for the Lamp, clamp onto horizontal face only.
- **Note:** The Lamp is not waterproof - Do not use outdoors or in wet areas
- Place the Lamp Arm with 12.7mm diameter Pin into the lamp base.  
Retain the Lamp in Base by tightening the side screw. To secure well use a screwdriver.
- Please use only with the Plug-In Power supply supplied.  
Connect the cord by pushing the co-axial Cord Connectors together before plugging into your wall socket.
- To switch ON, Touch on  Top of Lamp Head.
- The lamp has 3 selectable light levels 100% > 40% > 10%
- Each Touch steps the Light level down.
- Touch again to turn OFF.

### Important:

- The 2 Wing Knobs must be adjusted as desired, so the Lamp stays in position when moving to different positions.
- Do not move the lamp arm to the extreme limit's forwards and backwards which may cause irreparable damage.
- Do not hang off the arm or the head or hang any items from the lamp.
- Clean the lamp with a dry cloth.
- This product has an Integral LED and has no user serviceable parts. Do not dismantle.
- Do Not cover the Lamp or place against flammable materials.
- If the Power supply adaptor is damaged ensure it is replaced.
- The manufacturer will not be responsible for any damage caused by misuse or modification of this product.

### Optional Lamp bases are available:

Drawing Board Bracket	<b>LSM-1</b>
Wall bracket	<b>LSM-3H</b>
Bench Bracket	<b>LSM-4</b>
Heavy Table base	<b>LSM-7</b>
Floor Base	<b>LSM-9</b>

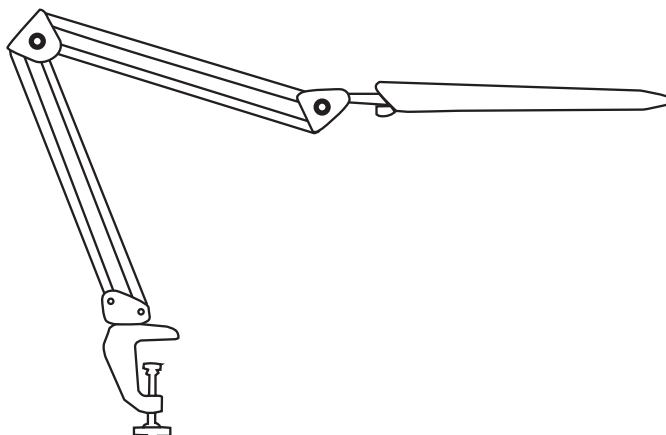

Keep these instructions for future reference

[www.superlux.co.nz](http://www.superlux.co.nz)